

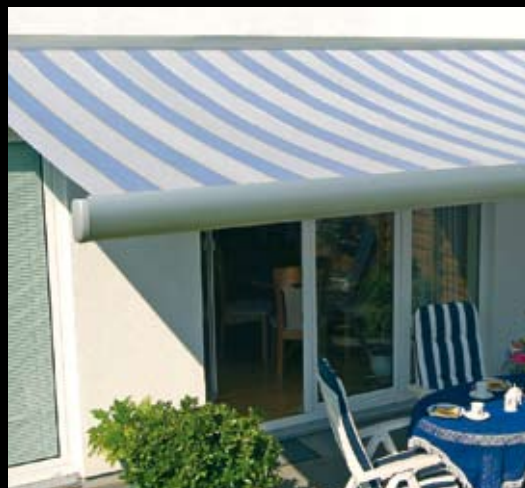

LEVA FOLDING ARM AWNING

Leva Folding Arm Awning is the ideal solution whenever functionality and uncompromising design are regarded as being equally important.

- ▶ Providing up to 14000mm of coverage in width and 4000mm in projection the Leva has been specifically designed for hospitality, commercial buildings and quality residential projects.
- ▶ A heavy duty torque bar partnered with our Supa-Kombi arm achieves high lateral stability. Multiple covers are linked with a single continuous canopy providing endless sizing options and economical solutions for large areas.
- ▶ All moving components are made of drop forged aluminium with durable baked enamel finish, while Teflon coated brushes provide maintenance free arm performance and consistent fabric tension.
- ▶ Our textiles offer the very best compromise between visibility and light transmission while providing incomparable weather resistance and ease of maintenance.
- ▶ Designed, engineered and manufactured in Germany. Certified ISO 9001: Safety tested by German TUV (Product Service).  MADE IN GERMANY



LEVA FOLDING ARM AWNING SPECIFICATIONS

Please note illustrations are not to scale. All measurements are in millimetres. Please contact your Viva Sunscreens representative for additional information.

FIXING METHODS

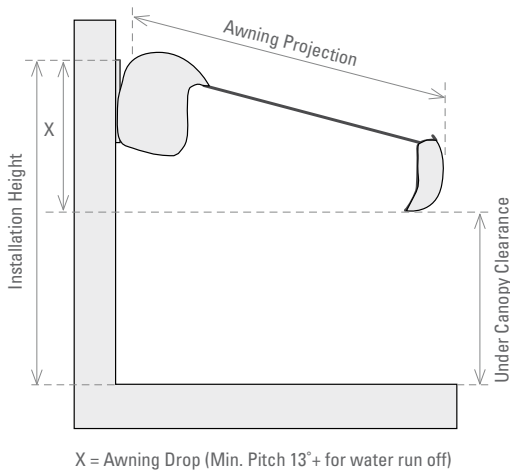
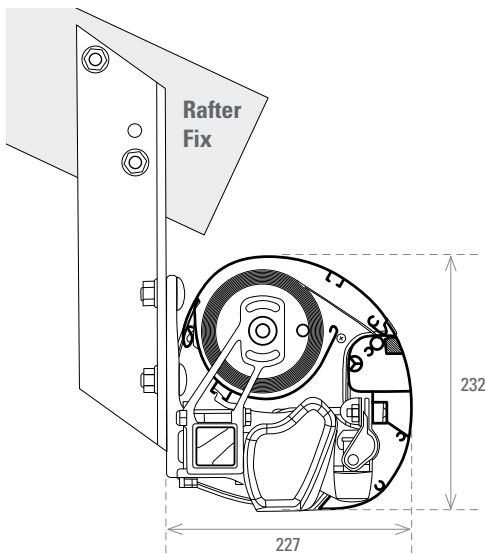
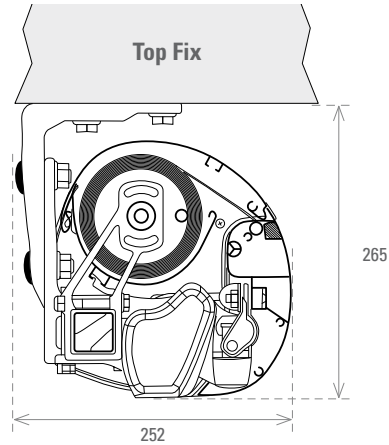
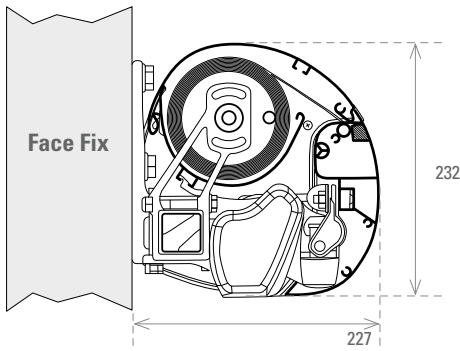

AVAILABLE SIZES

WIDTH	Max. 14000mm (over 7000mm coupled fabric applies) / Min. 2000mm
PROJECTION	Max. 4000mm / Min. 1500mm

HEADBOX

MATERIAL	6061 grade extruded aluminium
DIMENSION	Height: 232mm top/bottom, Depth: 227mm front/back
FINISH	Three standard colours and 300 colours available in the European RAL Powder Coat Range

TOP ROLLER

MATERIAL	80mm diameter heavy-duty extruded aluminium
----------	---

ARM ASSEMBLY

MATERIAL	6061 grade powder coated extruded aluminium with 4mm wall thickness
INTERNAL SPRING ASSEMBLY	Heavy-duty 8 gauge tensile steel dual spring assembly with dual 3mm PVC coated 316 stainless steel cable providing unparalleled fabric tension. Teflon coated bushes provide maintenance free performance

END CAPS

MATERIAL	Powder coated cast aluminium providing a minimal profile appearance ideal for reveal installations
----------	--

FIXING METHODS

TYPE	Face fix, top fix and rafter fix options available
MATERIAL	Powder coated drop forged aluminium bracket assembly
TORQUE BAR	Powder coated galvanised steel square section

CONTROL OPTIONS

CRANK OPERATION	Cast aluminium, 5.1 ratio, Gear 130X with extruded aluminium crank mechanism
ELECTRIC MOTOR	Tubular motor mounted internally within top roller. Aluminium case complete with built-in limit switches. Extensive range of control options available

FABRIC OPTIONS

MARINE GRADE ACRYLIC	100% dope dyed acrylic "Sunacrylic" fibre - Orchestra, Symphony, Opera ranges are available
SUNSCREEN MESH	High tenacity polyester core yarn sunscreen - Oxygen S5 (5% openness) S15 (%15 openness) ranges

STANDARD COLOUR OPTIONS OR CUSTOM COLOUR ON REQUEST

White/RAL 9016

Natural Anodised

Light Ivory/RAL 1015

P 1300 78 28 78

E products@vivascreens.com

Sydney Awning Centre:

1/6 Herbert Street, St. Leonards, NSW 2065

Melbourne Awning Centre:

393 Swan Street, Richmond, Victoria 3121