

Mechanical Specifications - dimensions are in mm

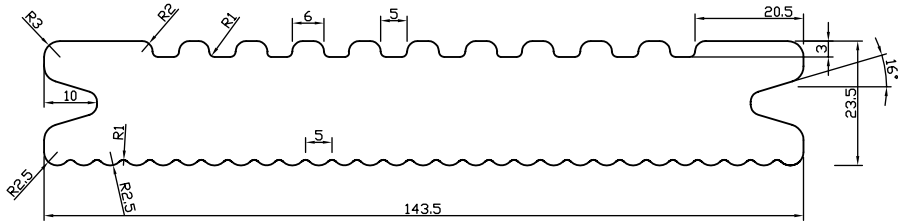

Fixing Centres

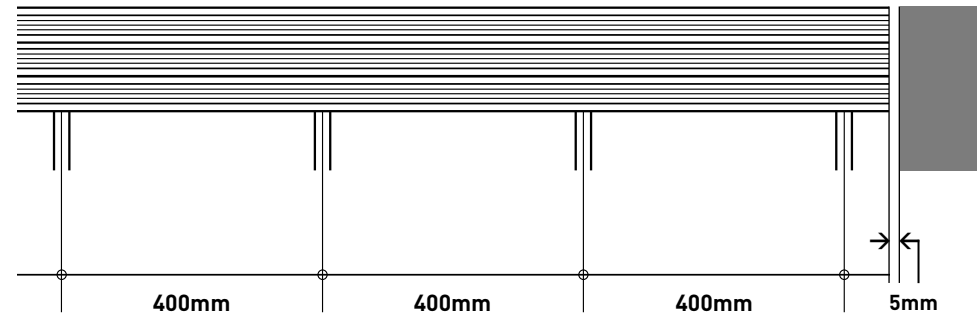

Fixing System - concealed stainless steel components



Size
143mm x 23.5mm

Spans
400mm on-centre

Lengths
5.6 metre

Weight
3.12kg/lineal metre

Composite
60% recycled wood fibre
40% recycled plastics -poly-olefin

Finish
Brushed surface

Colours
Ash Grey - Bahama Brown

Cut & Shaped
Use of current carpentry tools

Top Fixing
Pre-drill for fixing with screws

Standards

Fire Test
AS/NZS 3837:1998 (Bushfire)
AS/NZS 1530.3:1999
AS ISO 9239.1:2003

Slip Resistance
AS/NZS 4856:2004 (Appendix A,B,C,D)



Care and Performance
When required sweep, clean with water or water and detergent. No sanding or applying of oil or surface treatment is required nor recommended.