

hansgrohe

World of Styles.

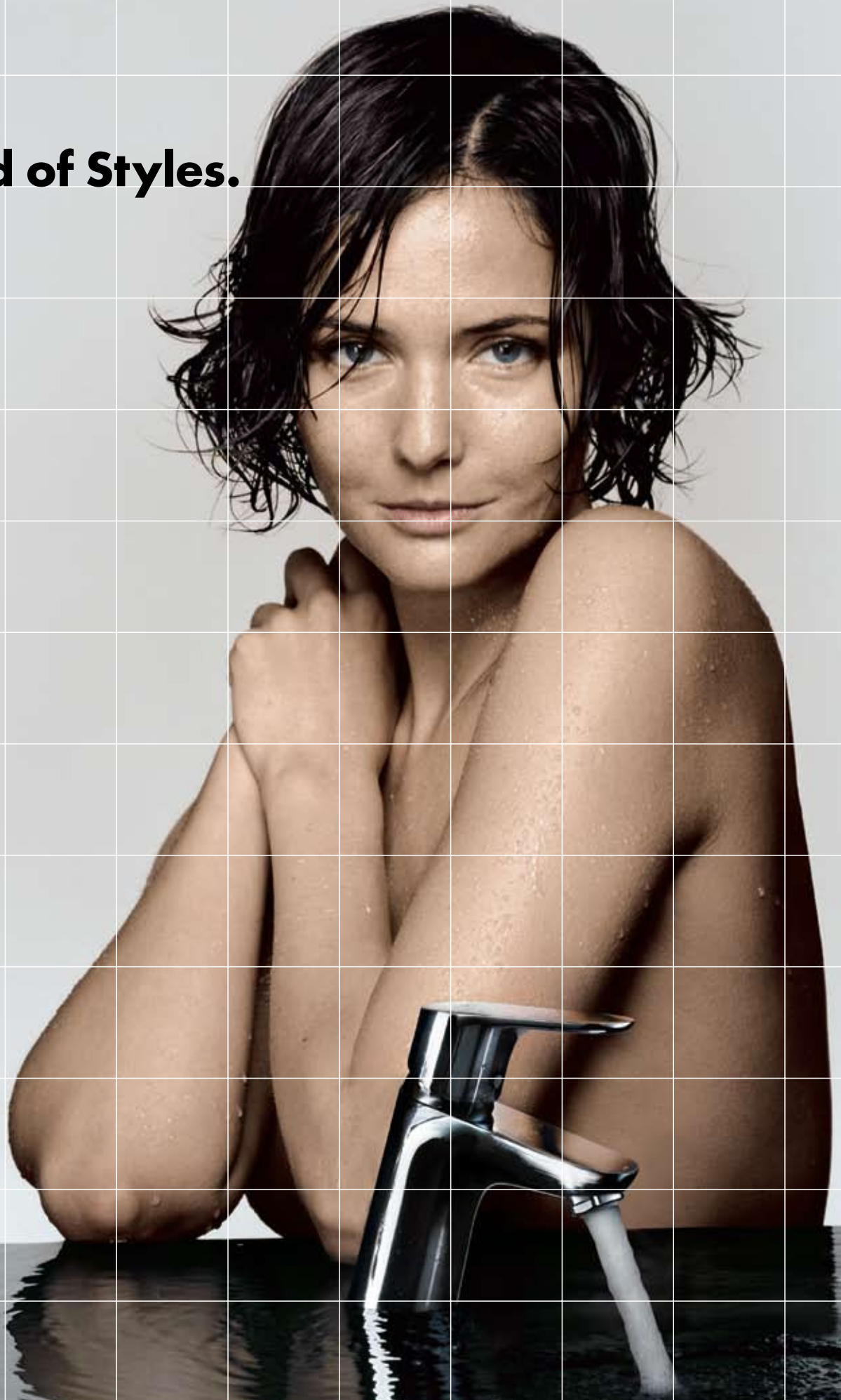



QuickClean®. No chance for lime scale thanks to the QuickClean anti-lime scale function. Lime scale on the elastic silicone nipples can be simply rubbed off.



Focus® S. Cylinder, sphere and cone – these geometric shapes are the foundation of the FocusS mixer line. Its characteristic feature is the slim, straight pin handle which makes it a pleasure to operate.



Focus S – Basin Mixer
WELS 4★ (7L/min)
#109950

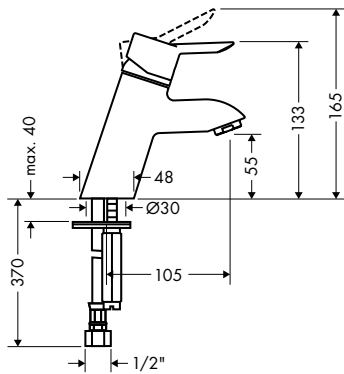

Focus S – Sink Mixer
WELS 4★ (7L/min)
#109952

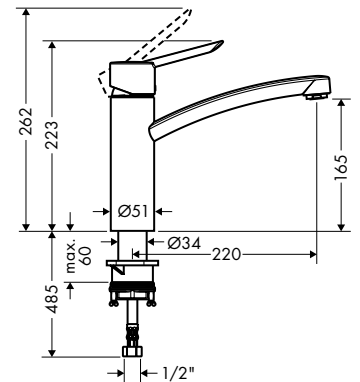

Focus S – Bath/Shower Mixer (trim only)
#109951

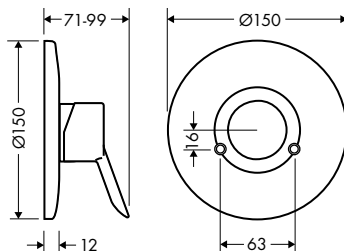

Focus S – Bath/Shower Mixer (body only)
#109956

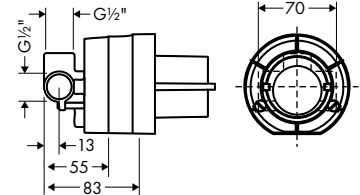

Focus® E. Dynamic silhouette, ergonomic handle, flattering curves – the design of the new FocusE mixers clearly reflects the ‘elegance’ philosophy. Exuding simplicity and exceptional quality.

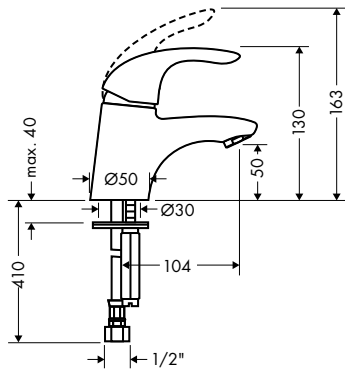

Focus E – Basin Mixer
WELS 4★ (7L/min)
#109953

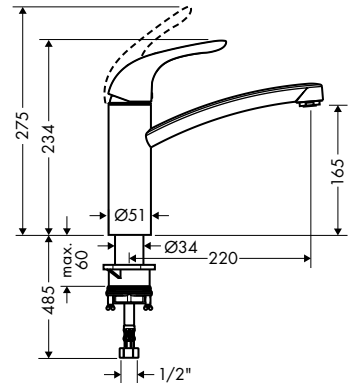

Focus E – Sink Mixer
WELS 4★ (7L/min)
#109955

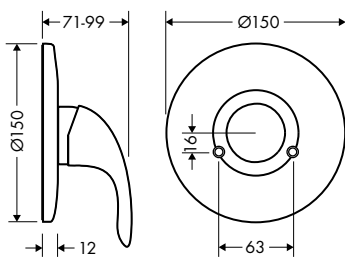

Focus E – Bath/Shower Mixer (trim only)
#109954

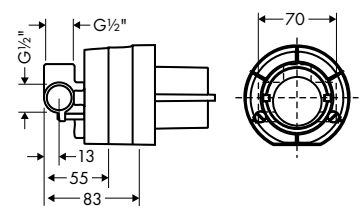

Focus E – Bath/Shower Mixer (body only)
#109956

Croma®. Big and beautiful – with its large spray surface, provides an expansive, soft shower rain and its clear design with ergonomic handle also goes perfectly with any bathroom.



Croma – 1-Jet
Shower on Rail
WELS 3★ (9L/min)
#109958

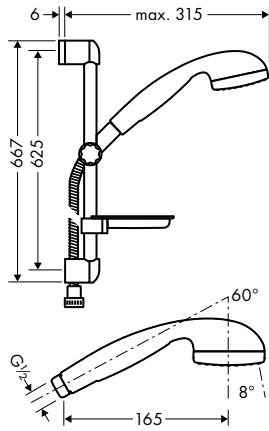

Croma – 2-Jet Shower Head
(shower arm not included)
WELS 3★ (9L/min)
#109962

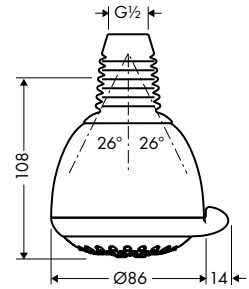

Crometta® 85. Superior functions, attractive spray modes and the unmistakable quality – the Crometta 85 has everything you need for a great shower experience.



Crometta 85 – Vario
Shower on Rail
WELS 3★ (9L/min)
#109959

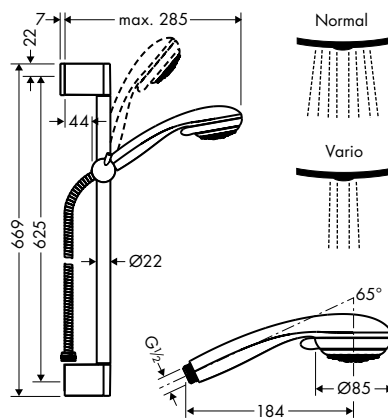

Raindance®



Raindance®. Innovative, functional, stylish – and ideal as part of a bathroom renovation. With its short handle, super-slim design and an extraordinarily large shower head, its only logical that a large shower can do more.

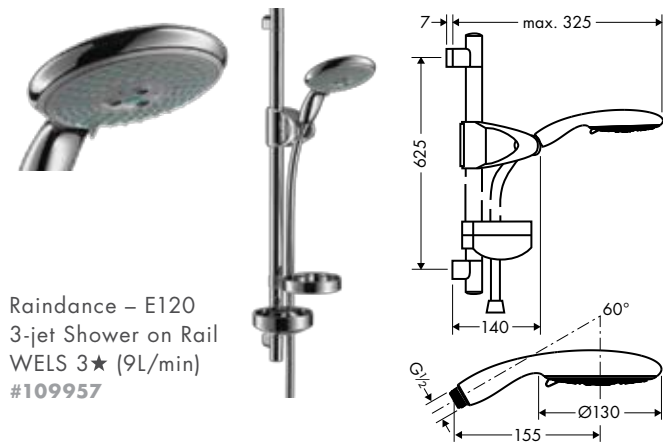

Raindance – E120
3-jet Shower on Rail
WELS 3★ (9L/min)
#109957

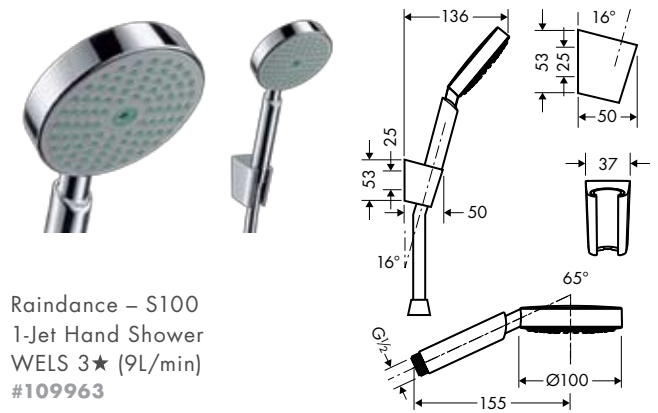

Raindance – S100
1-Jet Hand Shower
WELS 3★ (9L/min)
#109963

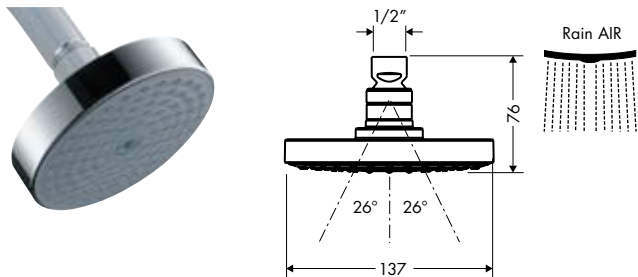

Raindance – S150 1-Jet Shower Head
(shower arm not included)
WELS 3★ (9L/min)
#109961



Raindance – S150 3-Jet Shower Head
(shower arm not included)
WELS 3★ (9L/min)
#109960

Powered by AIR. At Hansgrohe every drop counts. Impressive proof of this is the latest technological innovation – AIR, from now on is used in all Raindance showers. Mixed with air, the out-flowing water becomes softer or harder, depending on the spray mode – and the daily shower becomes a feast for the senses.

For your eyes: You can truly see the enclosed air in the voluminous drops. For your ears: Like a shower of rain, the AIR sound has a calming as well as vitalising effect. And for the skin, our largest and most sensitive sense organ: The water enriched with air completely covers the body in a pleasant layer of water and air. “Powered by AIR” – with this unique technology Hansgrohe creates a new quality and sets a new shower standard. Mixing it with air reduces water consumption by about 10 % and improves the quality of the spray jet.

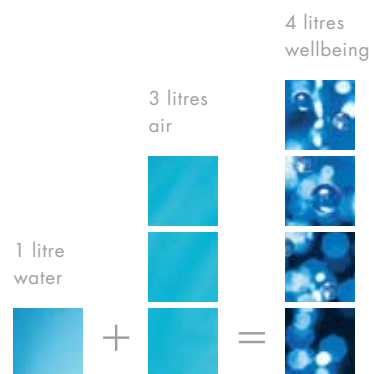

The AIR principle: 1 litre of water is enriched with 3 litres of air in the shower head. The result: Millions of warm, soft rain drops with Rain AIR, strong massage jet with Whirl AIR.



Available from:

mico

02 8354 0999
www.mico.com.au

Tradelink

1800 228 476
www.tradelink.com.au

DARWIN PLUMBING SUPPLIES

08 8947 1555

H&L
BUILDERS SUPPLIES

07 5578 2933

Warranty

All Hansgrohe products carry a comprehensive 5 year guarantee, except for shower hoses which carry a 1 year guarantee, from date of purchase, provided they are installed according to our specifications, by a licensed plumber.

All information contained in this brochure should serve as a guide only and is subject to change without notice. Crane Distribution Limited does not invite any person to act or rely upon such information and liability for such information is excluded. Without limitation colours, styles and brands shown in this brochure are indicative only and should not be relied upon. No representation is made regarding the types of use or availability of such items from Crane Distribution Limited stores. Ancillary products in this brochure such as tapware, bathroom furniture and bathroom accessories are shown for marketing purposes only and may not be available in Australia.

Tradelink, Mico Design, H&L and Darwin Plumbing Supplies are business names of Crane Distribution Limited, ABN 29 000 003 832, National Support Office, 1051 Nudgee Road, Banyo, QLD 4014. © Crane Distribution Limited.

Reorder code: 119900.