

environmental management system

Summary

Thinking Ergonomix has implemented an Environmental Management System (EMS) in order to identify environmental aspects arising from our operations with the intention of improving our environmental performance.

Described below are the environmental aspects that have been identified with a brief description of targets and programmes that have been or will be implemented.

Design and Development

All new design briefs to include environmental considerations. Design team uses an "environmental design checklist" which includes items such as recyclability, ease of disassembly, minimization of materials, etc.

Use of Energy

Analyse current energy (i.e. mainly electricity) usage. In 2008 we will carry out maintenance on factory compressor lines in order to improve electricity consumption. We will purchase at least 10% Green Power by the end of 2008.

Reviews are conducted every 3 months. A review committee has been established to set, record and review targets.

Emissions

Gas and liquid polluting emissions to air, land and water caused by Thinking Ergonomix operations are negligible due to the nature of the manufacturing process.

Reviews are conducted every 3 months. A review committee has been established to record and review any changes to our manufacturing processes that may effect emissions.

Material Minimisation

Analyse existing work practices to minimise the amount of waste produced from the manufacturing process.

New designs must adhere to the environmental considerations set in the

design briefs which include Material minimisation.

Reviews are conducted every 3 months. A review committee has been established to set, record and review targets.

Manufacturing Processes

Compile a list of all relevant manufacturing processes with detail of the potential environmental impacts e.g. energy consumed, waste produced, etc. and determine which the preferred processes are where there are a number of alternatives.

Packaging

Reduction in volume included in design brief for all new packaging. Box "buy-back" programme (for re-use of boxes in good condition) commenced early 2006. All packaging is currently recyclable except foam wrap – currently investigating alternatives. In 2008 our new packaging will incorporate pulp moulds made from 100% recycled cardboard.

Transportation

Establish a method of despatch that minimises the number of trips and cost of freight, while still maintaining optimum customer service. Optimise purchase of components to minimise number of trips and cost of freight. Purchase of carbon credits to offset greenhouse gas emissions produced by staff and company-owned vehicles.

Environmental Performance of Contractors and Suppliers

Incorporate environmental specifications in purchase orders covering issues such as:

- Minimisation of packaging
- Recycled packaging
- Recyclable packaging
- Recycled content of materials
- Request for supporting documentation.

Waste Management

Establish a benchmark of current performance and identify ways of reducing waste produced. Currently all waste is sorted and metal, plastic and paper/cardboard are recycled. As our sales increase, we aim to maintain the same volume of waste disposed, or better.

Reviews are conducted every 3 months. A review committee has been established to set, record and review targets.

End-of-Life

Our objective is to continue to produce products which are easily disassembled for recycling at end-of-life. Our end-of-life return policy is attached.

Legal and other Requirements

Our aim at Thinking Ergonomix is to not only meet, but in many cases, exceed the legal and regulatory environmental requirements currently in place.

Competence, training and awareness

Our staff members have attended and will continue to attend relevant seminars and training courses regarding environmental issues in our industry. It is the role of the environmental engineer to ensure that all staff members are aware of environmental aspects of our operations.

Communication

Issues arising from the EMS are communicated to staff, customers and suppliers via electronic media, printed documentation and face-to-face meetings.

Review

The EMS is a "living" system, subject to continual review and revision as new issues arise and targets are met. Our aim is to establish a benchmark of current performance and continually improve on this via the implementation of the programmes described within the EMS documentation.

environmental policy

Thinking Ergonomix is dedicated to the principle of sustainable design and development. We believe in minimising the environmental impact of our products throughout their life cycle and within the manufacture and use of our products. We believe this is our responsibility towards future generations.

We do this by:

- implementing an environmental management system in accordance with ISO14001 to monitor our environmental performance and to set environmental objectives and targets that are under constant review
- complying with relevant legislation and regulations and having due regard to changing community standards
- meeting industry best practice
- continuing an improvement in:
 - the reduction in the consumption of resources
 - the reduction of waste produced
 - the prevention of pollution to the environment
 - design for the environment

Thinking Ergonomix makes a commitment to this environmental policy and will continue to develop areas of improvement.

Dean Kuch
Managing Director

end-of-life return policy

As part of our commitment to product stewardship, Thinking Ergonomix encourages our customers to return our products to us at the end of their useful life. Depending on their condition, the products will either be refurbished or recycled.

If returning the goods to us is not viable, Thinking Ergonomix encourages the reuse of our products where possible or otherwise, please dismantle and recycle.

Dean Kuch
Managing Director



trapeze table base

product warranty

Thinking Ergonomix Pty Limited ABN 63 095 989 638 of 6A Childs Road, Chipping Norton NSW 2170, warrants its TRAPEZE range of product(s) to be free from defects in materials and workmanship under normal use for the period of ten (10) years.

This Warranty only applies to TRAPEZE products used by the original end user in Australia in accordance with instructions published by Thinking Ergonomix.

This Warranty does not cover:

- parts that are subject to normal wear and tear in use, including castors and coated surfaces;
- damage or deterioration due to normal wear and tear;
- damage due to improper installation of the product(s); or
- damage due to improper handling or inappropriate use of the Product(s), or neglect or malicious or deliberate act.

Thinking Ergonomix will repair or replace any defective part during the warranty period. Before a product can be returned to Thinking Ergonomix our customer must determine that the original end user has taken all reasonable steps to ensure that the product has been properly installed and operated in accordance with published operating instructions.

To make a claim under this Warranty our customer must contact Thinking Ergonomix, on (02) 9726 7177, and obtain a Warranty Return Authorization (WRA) in advance of shipment. Thinking Ergonomix will need certain information to process a warranty claim including the purchase details and a description of the product, proof of purchase of the product by the original end user and a contact name, address and telephone number.

If the product returned is found to have a defect that is covered by this Warranty, Thinking Ergonomix will bear the cost of the freight, otherwise the cost of freight and a reasonable administration charge shall be borne by the customer.

Limitation of Liability

Thinking Ergonomix's liability under this Warranty shall be limited to the original selling price of the product(s) to Thinking Ergonomix's customer. To the extent permitted by law, Thinking Ergonomix and its servants and agents are not liable for any loss or damage (including without limitation loss or damage caused by the negligence of Thinking Ergonomix, or its servants or agents, and incidental and consequential loss or damage) arising from or in connection with the supply of the product(s), including in relation to the use of, or inability to use, the product(s). Thinking Ergonomix is not liable for any loss or damage suffered if Thinking Ergonomix cannot do what it has promised because of events beyond its reasonable control.

Privacy

In order to conduct our business, Thinking Ergonomix needs to collect, use and disclose certain personal information about individuals, in particular our customers or end users (or individuals associated with our customers or end users). We respect the privacy of those individuals, and will ensure that we deal with their personal information in accordance with the National Privacy Principles under the Privacy Act. The main purposes for which we collect, use and disclose personal information are to provide and promote our products and services, conduct our internal administration, administer warranties and manage our business relationships. We will not use or disclose personal information for other purposes unless permitted to do so by the National Privacy Principles. We will take reasonable steps to ensure that all personal information we collect, use or disclose is accurate, complete, up to date, stored in a secure environment and accessed only by authorised personnel for permitted purposes. Please contact Thinking Ergonomix if you would like further information or you have any concerns about our management of personal information; or you would like access, in accordance with the National Privacy Principles, to any personal information that we may have collected about you.

trapeze table base

disassembly diagram

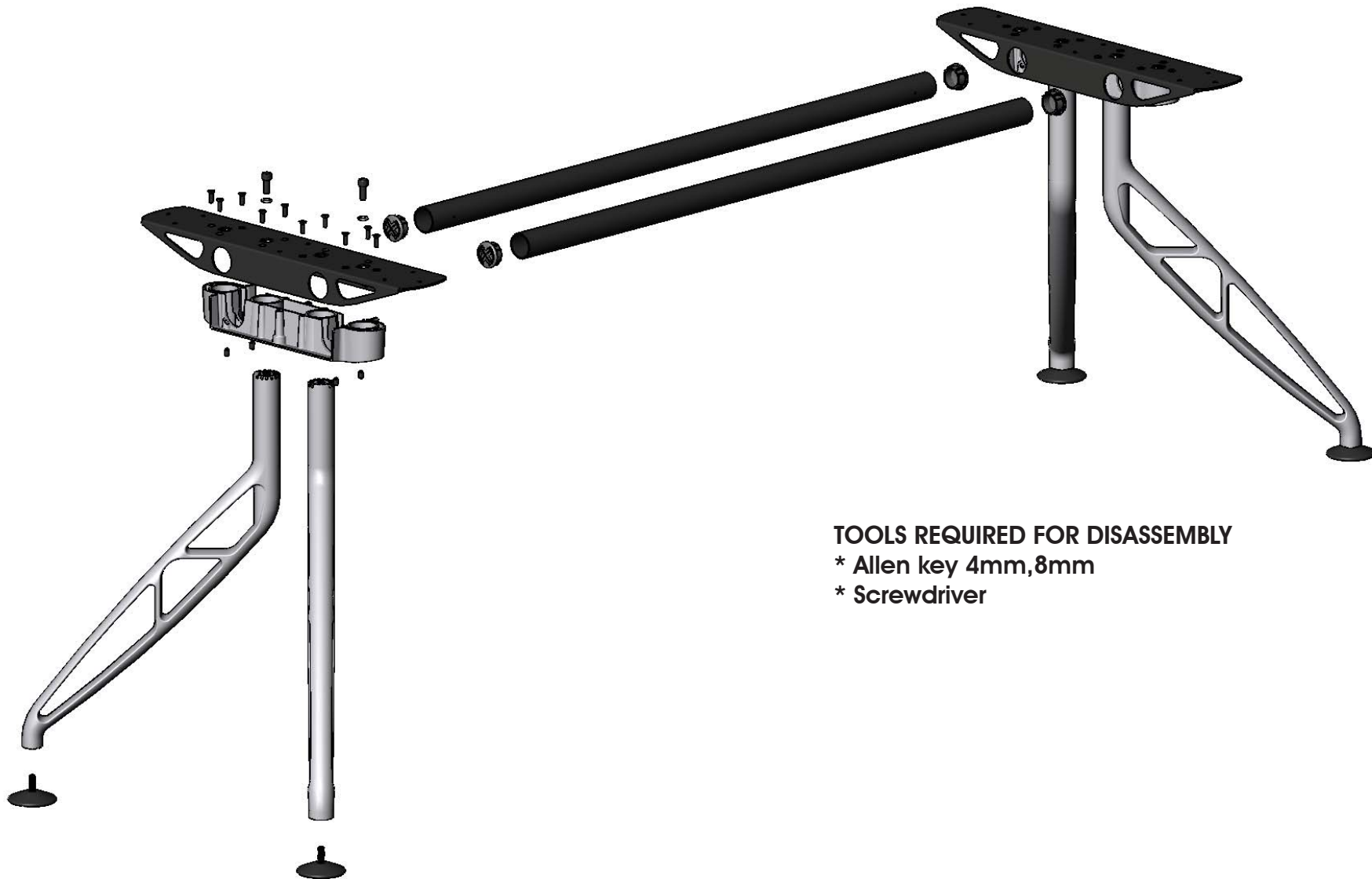

TOOLS REQUIRED FOR DISASSEMBLY

- * Allen key 4mm,8mm
- * Screwdriver

trapeze table base

component breakdown

Breakdown of Components by Material with Mass after Disassembly (For tools required please see Disassembly Diagram)

Trapeze

<i>Part</i>	<i>Description</i>	<i>Qty</i>	<i>Mass(kg)</i>	<i>% of total mass</i>
Steel Components				
Trapeze Horn	Powdercoated steel	2	5.20	20.7%
Rails	Powdercoated steel	2	4.60	18.3%
Aluminium Components				
Trapeze Foot	Aluminium	4	14.6	58.0%
Steel Alloy Components				
6G Screw	Zinc plated alloy steel	8	0.02	0.1%
Washer M12 Spring	Zinc plated alloy steel	4	0.03	0.1%
Bolt Hex M12 - zinc	Zinc plated alloy steel	4	0.03	0.1%
Screw 12G x 1"	Zinc plated alloy steel	12	0.06	0.2%
Plastic and Rubber Components				
Figure Rail Spacer	Polypropylene	2	0.04	0.2%
Figure Rail End cap	Polypropylene	4	0.04	0.2%
Other Components				
Glide	Polypropylene with threaded steel post	4	0.56	2.2%
Total mass			25.18	

trapeze table base

volatile organic compounds (VOCs)

The materials used in the trapeze range are; mild steel, aluminium, polypropylene, and steel alloy.

Aluminium parts are polished. Mild steel components are painted using the powder coat method which does not utilise any solvents. Low or no off-gassing of VOCs should therefore occur.

Dean Kuch
Managing Director